

# A1

« Scroll Chucks series »

## 3-JAW A1 TYPE CHUCKS



### ■ DIMENSIONS

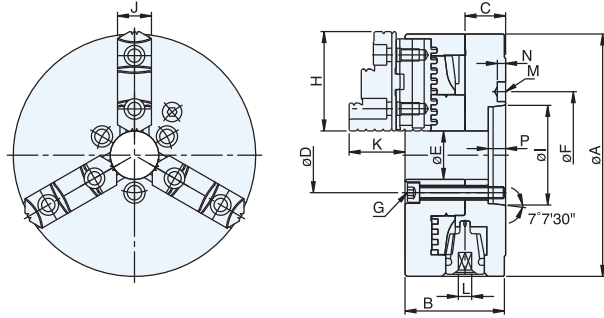

### ■ SPECIFICATIONS

UNIT:mm

| MODEL / SPEC. | A   | B    | C    | D     | E  | F      | G           | H  | I       | J  | K  | L  | P     | M     | N   | Max.Speed<br>r.p.m.(min <sup>-1</sup> ) | Max.Gripping Diameter |                  | Weight<br>(kg) |
|---------------|-----|------|------|-------|----|--------|-------------|----|---------|----|----|----|-------|-------|-----|---|-----------------------|------------------|----------------|
|               |     |      |      |       |    |        |             |    |         |    |    |    |       |       |     |   | O.D.<br>Clamping      | I.D.<br>Clamping |                |
| A.5-08"       | 200 | 83   | 33.5 | ø61.9 | 40 | ø104.8 | 3-M10x1.5P  | 82 | 82.563  | 28 | 43 | 11 | 14.29 | ø16.3 | 7.3 | 2000                                    | ø8-ø180               | ø62-ø170         | 17.4           |
| A.6-08"       | 200 | 83   | 33.5 | ø82.6 | 56 | ø133.4 | 3-M12x1.75P | 82 | 106.375 | 28 | 43 | 11 | 15.88 | ø19.3 | 7.5 | 2000                                    | ø8-ø180               | ø62-ø170         | 18             |
| A.6-10"       | 255 | 91.5 | 36.5 | ø82.6 | 56 | ø133.4 | 3-M12x1.75P | 93 | 106.375 | 32 | 50 | 12 | 15.88 | ø19.3 | 7.5 | 1800                                    | ø11-ø240              | ø70-ø230         | 30.6           |

# SO

« Scroll Chucks series »

## POWER SOFT JAWS



### ■ DIMENSIONS

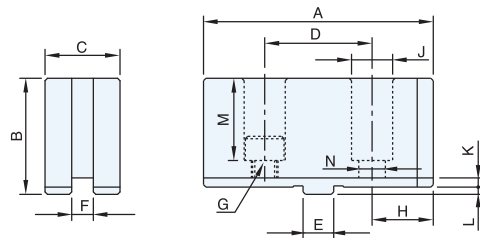

### ■ SPECIFICATIONS

UNIT:mm

| MODEL / SPEC. | A   | B  | C  | D    | E     | F    | G         | H     | J  | K   | L | M  | N  | Weight<br>(kg) |
|---------------|-----|----|----|------|-------|------|-----------|-------|----|-----|---|----|----|----------------|
| SO06Jaw       | 73  | 37 | 26 | 38.1 | 12.68 | 7.94 | M8x1.25P  | 17.45 | 14 | 3.5 | 3 | 25 | 9  | 1.3            |
| SO07Jaw       | 95  | 48 | 31 | 44.4 | 12.68 | 7.94 | M10x1.5P  | 25.3  | 17 | 3.8 | 3 | 34 | 11 | 2.6            |
| SO09Jaw       | 110 | 48 | 37 | 54   | 19.03 | 12.7 | M12x1.75P | 28    | 19 | 4.2 | 3 | 34 | 13 | 3.6            |
| SO12Jaw       | 125 | 54 | 42 | 63.5 | 19.03 | 12.7 | M12x1.75P | 30.75 | 19 | 4.2 | 3 | 38 | 13 | 5.5            |
| SO16Jaw       | 160 | 70 | 50 | 76.2 | 19.03 | 12.7 | M16x2P    | 41.9  | 25 | 5.5 | 6 | 48 | 17 | 10.4           |